	Report No: R2075		
	Issue No: 1		
	Test No: T1622	Test Report	Page: 1 of 31



dB Technology
 |----- (Cambridge Ltd.) -----|
 EMC Testing EMC Consultancy EMC Training

23, Headington Drive,
 Cambridge.
 CB1 9HE
 Tel : 01954 251974 (test site)
 or : 01223 241140 (accounts)
 Fax : 01954 251907
 web : www.dbtechnology.co.uk
 email: mail@dbtechnology.co.uk

REPORT ON ELECTROMAGNETIC COMPATIBILITY TESTS

**Performed at:
 TWENTY PENCE TEST SITE**

**Twenty Pence Road,
 Cottenham,
 Cambridge
 U.K.
 CB4 8PS**

on

AVO Systems Ltd

CT4 Camera

dated

1 September 2005

Document History

Issue	Date	Affected page(s)	Description of modifications	Revised by	Approved by
1	07/09/05		Initial release		

Based on report template:
 v031111

*This report shall not be reproduced except in full, without the written approval of:
 dB Technology (Cambridge) Ltd*

	Report No: R2075	
	Issue No: 1	
Test No: T1622	Test Report	
		Page: 2 of 31

Equipment Under Test (EUT): CT4 Camera

Test Commissioned by: AVO Systems Ltd
Unit 3
Dodnor Lane
Newport
Isle of Wight
PO30 5XA

Representative: David Barker

Test Started: 31st May 2005

Test Completed: 22 August 2005

Test Engineer: Dave Smith

Date of Report: 1 September 2005

Report:

Written by: Dave Smith Checked by: Derek Barlow

Signature: D. A. Smith Signature: D. Barlow

Date: 1 September 2005 Date: 7 September 2005

dB Technology can only report on the specific unit(s) tested at its site. The responsibility for extrapolating this data to a product line lies solely with the manufacturer.

Test Standards Applied

EN60945:2002	<i>Maritime navigation and radiocommunication equipment and systems - General requirements - Methods of testing and required test results</i>
	<i>EMC only (Sections 9 & 10)</i>

	Report No: R2075		
	Issue No: 1		
	Test No: T1622	Test Report	Page: 3 of 31

Emissions Test Results Summary

EN60945:2002

PASS

Test	Port	Method	Limit	PASS/FAIL	Notes
Conducted Emissions 10kHz-30MHz	ac power	CISPR16	EN60945	PASS	
Radiated Emissions 150kHz-30MHz		CISPR16	EN60945	PASS	
Radiated Emissions 30MHz-2GHz		CISPR16	EN60945	PASS	

marinev050601

	Report No: R2075	Test Report	Page: 4 of 31
	Issue No: 1		
	Test No: T1622		

Immunity Test Results Summary

EN60945:2002

PASS

Test	Port	Method	Severity	Perf. Criterion (Rec'd)	Criterion Ach'd	Notes
Radiated Field Immunity		IEC61000-4-3	10V/m 80-2000MHz 80%400Hz am mod	(A)	A	
Conducted RF Immunity	power signal/control	IEC61000-4-6	3Vrms 0.15-80MHz 80%400Hz am mod	(A)	A	
	power signal/control	IEC61000-4-6	10Vrms spot freq's 80%400Hz am mod	(A)	A	
Electrical Fast Transients	ac power	IEC61000-4-4	2kV	(B)	B	
	signal/control	IEC61000-4-4	1kV	(B)	B	
Electrostatic Discharge		IEC61000-4-2	8kV air	(B)	N/A	#1
		IEC61000-4-2	6kV contact	(B)	B	
Surge	ac power	IEC61000-4-5	0.5kV Line - Line 1.0kV Line - Earth	(B)	N/A	#2
Power supply variation	ac power	EN60945	+/- 20% voltage 1.5s	(B)	N/A	#2
	ac power	EN60945	+/-10% frequency 100msec	(B)	N/A	#2
Voltage Interrupt	power	IEC61000-4-11	100% reduction 60s	(C)	C	

marinev050601

- #1 Test not applicable because all accessible areas were conductive.
#2 Test not applicable because EUT had no ac power ports.

Performance Criterion (Rec'd) = Minimum performance criterion recommended by standards
Ach'd = Performance criterion achieved during actual test

	Report No: R2075	Test Report	Page: 5 of 31
	Issue No: 1		
	Test No: T1622		

Contents

1 EUT Details	6
1.1 General	6
1.2 Modifications to EUT and Peripherals	6
1.3 EUT Operating Modes	7
1.4 EUT Performance Criteria	7
<i>Figure 1 General Arrangement of EUT and Peripherals - Original System</i>	8
<i>Figure 2 General Arrangement of EUT and Peripherals - Modified System</i>	8
<i>Photograph 1 Conducted RF Immunity</i>	9
<i>Photograph 2 ESD</i>	9
2 Test Equipment	10
3 Test Methods	11
3.1 Conducted Emissions - ac power	11
3.2 Magnetic Field Emissions	11
3.3 Radiated Emissions	11
3.4 RF Fields Immunity	12
3.5 Conducted RF Immunity	12
3.6 Electrical Fast Transient Immunity	12
3.7 Electrostatic Discharge Immunity	13
3.8 Voltage Dips and Interruptions	13
4 Test Results	13
4.1 Conducted Emissions (Power) - Results	14
4.2 Magnetic Field Emissions Results - 0.15MHz to 30MHz	15
4.3 Radiated Emissions Results - 30MHz to 2GHz	16
4.4 RF Field Immunity Results - 80MHz to 1GHz	17
4.5 RF Field Immunity Results - 1GHz to 2GHz	18
4.6 Conducted RF Immunity Results	19
4.7 Electrical Fast Transient Immunity Results	20
4.8 Electrostatic Discharge Immunity Results	21
4.9 Voltage Dips Immunity Results	22
<i>PLOT 1 Conducted Emissions - Positive Line</i>	23
<i>PLOT 2 Conducted Emissions - Negative Line</i>	24
<i>PLOT 3 Radiated Emissions - 0.15MHz to 1MHz (face on polarisation)</i>	25
<i>PLOT 4 Radiated Emissions - 0.15MHz to 1MHz (side on polarisation)</i>	26
<i>PLOT 5 Radiated Emissions - 1MHz to 10MHz</i>	27
<i>PLOT 6 Radiated Emissions - 10MHz to 30MHz</i>	28
<i>PLOT 7 Radiated Emissions - 25MHz to 275MHz</i>	29
<i>PLOT 8 Radiated Emissions - 250MHz to 1GHz</i>	30
<i>PLOT 9 Radiated Emissions - 1GHz to 2GHz</i>	31

	Report No: R2075	Test Report	Page: 6 of 31
	Issue No: 1		
	Test No: T1622		

1 EUT Details

1.1 General

The EUT was a video camera.

Details of the EUT and associated peripherals used during the tests are listed below. Figure 1 shows the interconnections between the EUT and peripherals.

Item	Manufacturer	Model	Description	Serial No:	Notes
1	AVO Systems	CT4 camera	EUT	CT40025	
2	- Matsui	15-MC05	5" TFT LCD Monitor or TV	UK73015	
3	Genie	EPA-121DA-12	PSU or 12V bench PSU	-	

1.2 Modifications to EUT and Peripherals

Details of any modifications that were required to achieve compliance are listed below. The modification numbers are referred to in the results sections as appropriate.

Mod No:	Details	Implemented for
0	Original system.	
1	<p>Individual wires for 12V and 0V. Separate co-axial cable for video. Overall screen connected to camera case (using as short and wide a connection as possible). Overall screen continues over the DC cable to power supply and connects to RF reference (e.g. power supply chassis). Co-axial video cable screen connected to overall screen at point where DC cable separates.</p> <p>2* 100nF capacitors connected on camera PCB between 0V and 12V pads of cable connector. (Single 220nF capacitor could be used if available).</p> <p>These modifications are shown in Figure 2.</p>	<p>RF Immunity</p> <p>Conducted Emissions</p>

	Report No: R2075	Test Report	Page: 7 of 31
	Issue No: 1		
	Test No: T1622		

1.3 EUT Operating Modes

The EUT was tested in the following operating mode or modes. Generally, operating modes are chosen that will exercise the functions of the EUT as fully as possible and in a manner likely to produce maximum emission levels or susceptibility. Individual test result sheets reference the operating mode of the EUT.

Operating Mode	Details
1	Camera powered and connected to a monitor in order to display picture.

1.4 EUT Performance Criteria

To assess the immunity performance of the EUT the performance criteria listed below were applied. The criteria specify the functions that were monitored during the tests and the levels of performance that were considered acceptable.

Criterion	Details
A	Camera should continue to operate as normal during the test although some interference on the displayed picture is allowed providing the picture is still considered "viewable".
B	Temporary effects on the EUT are permitted during the test providing full automatic recovery is made after the test:
C	Full loss of functionality is permitted during the test providing recovery is possible after the test with the aid of user intervention if required:

Performance Criterion A is normally applied to tests where the phenomenon is likely to be continuous in nature - the EUT should continue to perform within the specified performance limits during the test. *Performance Criterion B* is normally applied to tests where the phenomenon is likely to be transient in nature - in this case temporary loss of performance is usually acceptable during the test as long as the EUT automatically returns to normal operation after the test.

Performance Criterion C is normally associated with power supply failures - in this case loss of performance is usually acceptable as long as the EUT can recover with the aid of user intervention if necessary.

	Report No: R2075	Test Report	Page: 8 of 31
	Issue No: 1		
	Test No: T1622		

Figure 1 General Arrangement of EUT and Peripherals - Original System



Original system:

Individual wires for 12V, 0V and video.
Overall screen not connected to camera case.

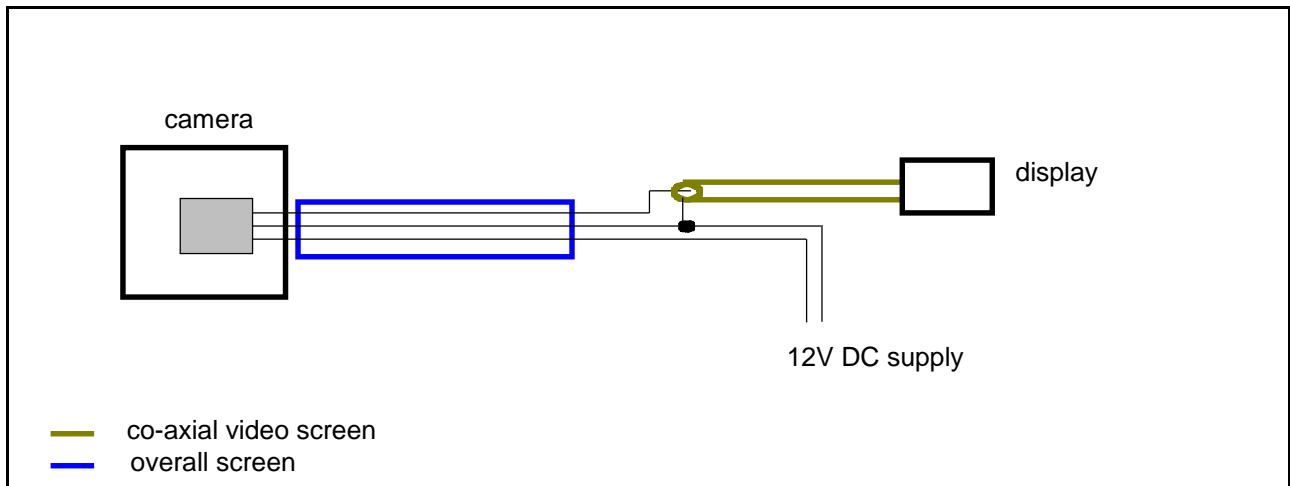
Figure 2 General Arrangement of EUT and Peripherals - Modified System

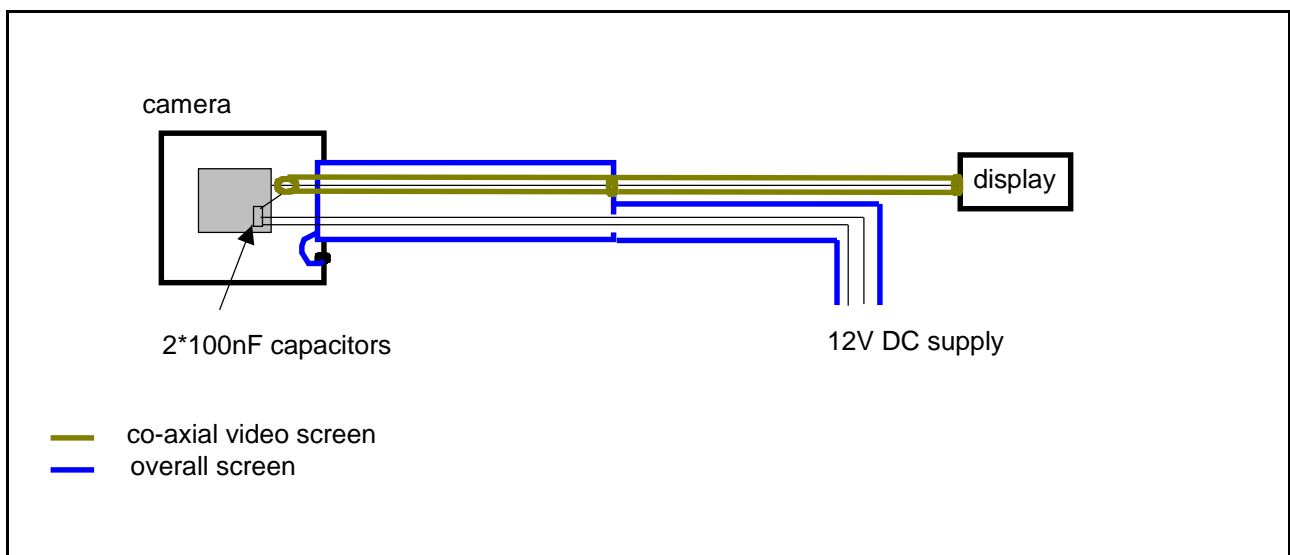

Modified system:

Individual wires for 12V and 0V. Separate co-axial cable for video.
Overall screen connected to camera case (using as short and wide a connection as possible).
Overall screen continues over the DC cable to power supply and connects to RF reference (e.g. power supply chassis).
Co-axial video cable screen connected to overall screen at point where DC cable separates.
2* 100nF capacitors connected on camera PCB between 0V and 12V pads of cable connector. (Single 220nF capacitor could be used if available).

	Report No: R2075	
	Issue No: 1	
Test No: T1622	Test Report	Page: 9 of 31



Photograph 1 Conducted RF Immunity



Photograph 2 ESD

*This report shall not be reproduced except in full, without the written approval of:
dB Technology (Cambridge) Ltd*

	Report No: R2075	Test Report	Page: 10 of 31
	Issue No: 1		
	Test No: T1622		

2 Test Equipment

The test equipment used during the tests was one or more of the items listed below. Individual test result sheets indicate which items were used.

Ref No:	Details	Serial Number
A12	Chase Bilog CBL6111A	1012
A4	Chase HFBilog CBL6112	2027
A5	Chase Bilog CBL6111A	1760
A8	EMCO 3115 DR Guide	6070
A9	EMCO 6502 Loop	2139
AMP1	KALMUS Power amp	72690
AMP2	KALMUS Power amp	7355C1
AMP4	dB AM28 1-2.5GHz Power Amp	1
CL1	CHASE CIC-8100 EM Clamp	138
CL3	Omiran EFT-HFK	382
DC004	Narda 3022 Directional Coupler 1-4GHz	7548
FP2	HOLADAY HI-6005 / HI4413P	102115
L1	EMCO 3825/2 LISN	1358
PM1	Marconi 6960A RF Power Meter	2785
PS2	Marconi 6920 RF Power Sensor	112
R1	CHASE LHR 7000	1056
R3	R&S ESHS10	84374.3
R4	R&S ESVS10	421872
R5	HP 8595E Spec. Analyser	3412A00701
R5B	dB Technology Pre-amp	dB001
SG1	Marconi 2022D	2384.32
SG9	HP 8648C 9kHz-3.2GHz Signal Generator	3847A05254
WG4a	UCS 500-M-EFT	1263
WG4d	UCS 500-M-ESD	1263
WGH3	EM Test P18	1299-36 (c/a)

	Report No: R2075	
	Issue No: 1	
Test No: T1622	Test Report	
		Page: 11 of 31

3 Test Methods

3.1 Conducted Emissions - ac power

This section describes the general method of performing this test. The specific method used and any deviations from this general method are listed in the appropriate results section.

Bench top EUTs and peripheral equipment are normally placed on a 0.8m high non-conducting bench, positioned 0.4m from one of the metallic walls of a screened room. Floor standing EUTs are normally placed 0.1m above the metallic floor of the screened room. Mains leads are bundled so as not to exceed 1m.

The EUT is powered using a 50ohm/50uH Line Impedance Stabilisation Network (LISN). Peripherals are powered using a second a 50ohm/50uH LISN. These LISNs are bonded to the screened room floor.

With the correct supply voltage applied to the EUT scans are performed on both the live and neutral line outputs of the LISN using quasi-peak detection over the specified frequency range. The results of these scans are shown in the plots section at the end of the report.

Significant emissions identified by the scans are measured and the results tabulated. The table of results is shown in the conducted emissions results section.

3.2 Magnetic Field Emissions

This section describes the general method of performing this test. The specific method used and any deviations from this general method are listed in the appropriate results section.

Initial scans are performed in a semi-anechoic screened room at a distance of 3m using an active loop antenna. Scans are performed over the frequency range specified in the test standard using an appropriate loop antenna. During these scans the EUT and peripherals are rotated through 360°. Bench top EUTs are placed on a non-conducting bench at a height of 0.8m above the ground plane. Floor standing EUTs are placed 0.1m above the ground plane. The results of the scans are shown in the plots included at the end of the report.

Significant emissions identified by the scans are measured on an open area test site at the appropriate test distance using a CISPR16 quasi-peak receiver. The open area test site does not have a ground plane. Maximised readings are obtained by rotating the EUT through 360°. The receiving antenna remains at a fixed height of 1m. Measurements are made with the receiving antenna both coaxial and perpendicular to the EUT.

3.3 Radiated Emissions

This section describes the general method of performing this test. The specific method used and any deviations from this general method are listed in the appropriate results section.

Initial scans are performed in a semi-anechoic screened room at a distance of 3m. Scans are performed over the frequency range specified in the test standard with the antenna both horizontally and vertically polarised. During these scans the EUT and peripherals are rotated through 360°. Bench top EUTs are placed on a non-conducting bench at a height of 0.8m above the ground plane. Floor standing EUTs are placed 0.1m above the ground plane. The results of the scans are shown in the plots included at the end of the report.

Significant emissions identified by the scans are measured on an open area test site at the appropriate test distance using a CISPR16 quasi-peak receiver. Maximised readings are obtained by rotating the EUT through 360° and adjusting the height of the antenna from 1m to 4m. Measurements are made with the antenna both horizontally and vertically polarised and the results tabulated.

	Report No: R2075	Test Report	Page: 12 of 31
	Issue No: 1		
	Test No: T1622		

3.4 RF Fields Immunity

This section describes the general method of performing this test. The specific method used and any deviations from this general method are listed in the appropriate results section.

Bench top EUT is placed on a non-conducting wooden bench at a height of 0.8m above the floor of an anechoic screened room. Floor standing EUT is placed 0.1m from the floor of the screened room. The transmitting aerial is placed at the relevant calibration distance from the EUT and driven by means of a power amplifier and signal generator. An isotropic field strength meter is placed on the bench adjacent to the EUT to monitor the local field strength.

The signal generator frequency is swept over the appropriate frequency range whilst the amplitude of the signal is controlled either:

- using the real-time field strength meter reading;

- using a profile previously determined in a calibration run without the EUT in place.

3.5 Conducted RF Immunity

This section describes the general method of performing this test. The specific method used and any deviations from this general method are listed in the appropriate results section.

The EUT and peripheral equipment are placed at a height of 0.1m above a ground plane.

AC input ports and other suitable ports are connected to CDNs (coupling decoupling networks).

An interference signal is derived from a signal generator and fed through a power amplifier and attenuator. The signal is applied in turn to each port tested via the CDN, an EM clamp or directly onto cable screens via 150R - the results table indicates the method of application.

The signal is swept through the appropriate frequency range and the output level adjusted to a level determined by the characteristics of the coupling device and the test level specified in the standard. The level of the applied signal was monitored using the forward power meter on the RF amplifier.

3.6 Electrical Fast Transient Immunity

This section describes the general method of performing this test. The specific method used and any deviations from this general method are listed in the appropriate results section.

Bench top EUT is placed on a non-conducting wooden bench at a height of 0.8m above a ground plane. Floor standing EUT is placed 0.1m above the ground plane. The EFT generator is bonded to the ground plane.

Electrical Fast Transients are applied to the power leads of the EUT via a coupling network. Electrical Fast Transients are also applied to signal and control leads exceeding 3m in length using a capacitive coupling clamp. Where required, the leads are extended to facilitate this.

	Report No: R2075	Test Report	Page: 13 of 31
	Issue No: 1		
	Test No: T1622		

3.7 Electrostatic Discharge Immunity

This section describes the general method of performing this test. The specific method used and any deviations from this general method are listed in the appropriate results section.

Bench top EUT is placed on thin insulating sheets positioned on a horizontal metal coupling plane. The coupling plane is 0.8m above a metallic ground plane and connected to it by discharge resistors with a total value of 1Mohm. Floor standing EUT is placed on, but insulated from, the ground plane / screened room floor. The ESD generator and the return cable of the discharge gun are both bonded to the ground plane.

For conductive areas of the EUT, contact discharge is made to the relevant accessible points. Where areas of the EUT are insulated and contact discharge cannot be performed, air discharge is performed. Contact discharge is also made to the horizontal coupling plane and to a vertical coupling plane at the side of the EUT.

For each location selected, ten discharges are performed at the appropriate levels and polarities.

3.8 Voltage Dips and Interruptions

This section describes the general method of performing this test. The specific method used and any deviations from this general method are listed in the appropriate results section.

The mains lead of the EUT was connected to a variable power source. The output of the power source is varied to simulate the specified voltage dips and interruptions.

4 Test Results

The following sections contain tabulated test results. Plots of various scans are included at the back of this section.

	Report No: R2075	Test Report	Page: 14 of 31
	Issue No: 1		
	Test No: T1622		

4.1 Conducted Emissions (Power) - Results

Factor Set 1:	L1_04B	CSET001_04A	-	-
Factor Set 2:	-	-	-	-
Factor Set 3:	-	-	-	-
Test Equipment: R1 L1 CSET001				

Conducted Emissions (Power)

<i>Company:</i> AVO Systems Ltd	<i>Product:</i> CT4 Camera
<i>Date:</i> 01/08/2005	<i>Test Eng:</i> Dave Smith
<i>Ports:</i> ac power	
<i>Test:</i> CISPR16 using limits of EN60945	
<i>Ports:</i>	
<i>Test:</i> using limits of	

Plot	Op Mode	Mod State	Line (L/N)	Fact Set	Freq. MHz	Det qp/av	Rec. Level dBuV	Corr'n Factor dB	Total Level dBuV	Limit EN60945 dBuV	Margin EN60945 dB	Notes
2	1	1	Neg	1	0.261	qp	37.7	10.2	47.9	53.5	5.5	
1	1	1	Pos	1	0.261	qp	38.0	10.2	48.2	53.5	5.2	

Results	Minimum Margin PASS/FAIL	5.2 dB PASS
----------------	------------------------------------	------------------------------

Notes	Comments and Observations
-------	---------------------------

	<p>Results of scans shown in plot 1 and plot 2.</p> <p>Two 100nF caps across 12V and 0V connector pads. Overall screened cable with co-axial video cable.</p>
--	-------------------------------------------------------------------------------------------------------------------------------------------------------------------

	Report No: R2075		
	Issue No: 1		
	Test No: T1622	Test Report	Page: 15 of 31

4.2 Magnetic Field Emissions Results - 0.15MHz to 30MHz

Factor Set 1:	A9_HI_V_04A	-	-	RG214_04A	50 m cable
Factor Set 2:	-	-	-	-	
Factor Set 3:	-	-	-	-	
Test Equipment: R3 A9 CSET005					

Radiated Emissions

<i>Company:</i> AVO Systems Ltd		<i>Product:</i> CT4 Camera	
<i>Date:</i> 31/05/2005		<i>Test Eng:</i> PB	
<i>Ports:</i>			
<i>Test:</i>	CISPR16	using limits of	EN60945
<i>Ports:</i>			
<i>Test:</i>		using limits of	
Notes	Comments and Observations		
	<p>Results of scans shown in plots 3 to 6.</p> <p>All emissions were sufficiently below the limit line that it was not considered necessary to maximise on the open area test site.</p>		

	Report No: R2075		
	Issue No: 1		
	Test No: T1622	Test Report	Page: 16 of 31

4.3 Radiated Emissions Results - 30MHz to 2GHz

Factor Set 1:	A4_10m_04A	-	-	RG214_04A	25 m cable
Factor Set 2:	-	-	-	-	
Factor Set 3:	-	-	-	-	
Test Equipment: R4 A4 CSET005					

Radiated Emissions

<i>Company:</i> AVO Systems Ltd					<i>Product:</i> CT4 Camera								
<i>Date:</i> 31/05/2005					<i>Test Eng:</i> PB								
<i>Ports:</i>													
<i>Test:</i> CISPR16					using limits of EN60945								
<i>Ports:</i>													
<i>Test:</i> using limits of													
Plot	Op Mode	Mod State	Dist m	Fact Set	Freq. MHz	Ant Pol	Rec. Level dBuV	Corr'n Factor dB/m	Corr'n Factor dB	Total Level dBuV/m	Limit EN60945 dBuV/m	Margin EN60945 dB	Notes
7	1	0	3	1	160.965	V	3.5	12.4		15.9	30.0	14.1	#1
7	1	0	3	1	160.965	H	9.5	12.4		21.9	30.0	8.1	#1
Results											8.1	dB	
											PASS		
Notes											Comments and Observations		
#1											Results of scans shown in plots 7 to 9. Using 10kHz bandwidth peak detector.		

	Report No: R2075	Test Report	Page: 17 of 31
	Issue No: 1		
	Test No: T1622		

4.4 RF Field Immunity Results - 80MHz to 1GHz

RF Immunity

<i>Company:</i> AVO Systems Ltd		<i>Product:</i> CT4 Camera	
<i>Date:</i> 22/08/2005		<i>Test Eng:</i> Dave Smith	
Test Equipment: SG9 AMP1 FP2 CSET003 A12			RESULT
<i>Ports:</i>		Recm'd Crit	Ach'd Crit.
<i>Tests:</i>	IEC61000-4-3 10V/m 80-2000MHz 80%400Hz am mod	(A)	A
<i>Ports:</i>		Recm'd Crit	Ach'd Crit.
<i>Tests:</i>			
<i>Ports:</i>		Recm'd Crit	Ach'd Crit.
<i>Tests:</i>			

Oper. Mode	Mod State	EUT orientation	Filename	Antenna	Frequency Range MHz	Step Size %	Sweep Time mins	Polarisation	Field Strength V/m	Modulation %AM / freq	Notes
1	1	side	021EC43E	A12	80-200	0.33	5.42	H	10	80%, 400Hz	#1
1	1	side	021EC6B7	A12	200-1000	0.33	8.95	H	10	80%, 400Hz	#1
1	1	side	021EC73A	A12	80-200	0.33	4.95	V	10	80%, 400Hz	#1
1	1	side	021EC780	A12	200-1000	0.33	8.70	V	10	80%, 400Hz	#1
1	1	front	021EC8E8	A12	80-200	0.33	5.05	H	10	80%, 400Hz	#1
1	1	front	021EC94F	A12	200-1000	0.33	8.72	H	10	80%, 400Hz	#1
1	1	front	021EC81C	A12	80-200	0.33	4.95	V	10	80%, 400Hz	#1
1	1	front	021EC867	A12	200-1000	0.33	8.83	V	10	80%, 400Hz	#1

V = Vertical, H = Horizontal polarisation #1, 2, 3.... see Observations Table below

Notes	Comments and Observations
#1	<p>No effect observed.</p> <p>Overall screen connected to case. Internal co-axial video cable. 200nF across 12V pins.</p>

	Report No: R2075	Test Report	Page: 18 of 31
	Issue No: 1		
	Test No: T1622		

4.5 RF Field Immunity Results - 1GHz to 2GHz

RF Immunity

Company: AVO Systems Ltd		Product: CT4 Camera	
Date: 22/08/2005		Test Eng: Dave Smith	
Test Equipment: SG9 FP2 PM1 PS2 AMP4 A8 CSET006 DC004			RESULT
Ports:		Recm'd Crit	Ach'd Crit.
Tests:	IEC61000-4-3 10V/m 80-2000MHz 80%400Hz am mod	(A)	A
Ports:		Recm'd Crit	Ach'd Crit.
Tests:			
Ports:		Recm'd Crit	Ach'd Crit.
Tests:			

Oper. Mode	Mod State	EUT orientation	Filename	Antenna	Frequency Range MHz	Step Size %	Sweep Time mins	Polarisation	Field Strength V/m	Modulation %AM / freq	Notes
1	1	side	021ECD7D	A8	1000-2000	0.33	3.90	H	10	80%, 400Hz	#1
1	1	side	021ECED5	A8	1000-2000	0.33	4.95	V	10	80%, 400Hz	#1
1	1	front	021ECDCC	A8	1000-2000	0.33	3.95	H	10	80%, 400Hz	#1
1	1	front	021ECE84	A8	1000-2000	0.33	4.67	V	10	80%, 400Hz	#1

V = Vertical, H = Horizontal polarisation #1, 2, 3.... see Observations Table below

Notes	Comments and Observations
#1	<p>Some interference observed on display at some frequencies. At all times picture was considered "viewable".</p> <p>Overall screen connected to case. Internal co-axial video cable. 200nF across 12V pins.</p>

	Report No: R2075	Test Report	Page: 19 of 31
	Issue No: 1		
	Test No: T1622		

4.6 Conducted RF Immunity Results

Conducted RF Immunity

Company: AVO Systems Ltd		Product: CT4 Camera	
Date: 01/06/05		Test Eng: Dave Smith	
Test Equipment: SG1 AMP2 CSET004 CL1			RESULT
Ports:	power	signal/control	Recm'd Crit
Tests:	IEC61000-4-6	3Vrms 0.15-80MHz	80%400Hz am mod (A)
			Ach'd Crit. A
Ports:	power	signal/control	Recm'd Crit
Tests:	IEC61000-4-6	10Vrms spot freq's	80%400Hz am mod (A)
			Ach'd Crit. A
Ports:			Recm'd Crit
Tests:			Ach'd Crit.

Test	Oper. Mode	Mod State	Cable	Filename	Coupler	Frequency Range MHz	Step Size %	Sweep Time mins	Modulation %AM / freq	Level Vrms	Notes
1	1	0	Power/video bundle	020925A4	CL1	0.15 - 80	0.33	27.42	80% 400Hz	3	#1
2	1	0	""	0209278A	CL1	2	-	-	80% 400Hz	10	#2
3	1	0	""	0209278A	CL1	3	-	-	80% 400Hz	10	#2
4	1	0	""	0209278A	CL1	4	-	-	80% 400Hz	10	#2
5	1	0	""	0209278A	CL1	6.2	-	-	80% 400Hz	10	#3
6	1	0	""	0209278A	CL1	8.2	-	-	80% 400Hz	10	#3
7	1	0	""	0209278A	CL1	12.6	-	-	80% 400Hz	10	#3
8	1	0	""	0209278A	CL1	16.5	-	-	80% 400Hz	10	#3
9	1	0	""	0209278A	CL1	18.8	-	-	80% 400Hz	10	#3
10	1	0	""	0209278A	CL1	22	-	-	80% 400Hz	10	#2
11	1	0	""	0209278A	CL1	25	-	-	80% 400Hz	10	#2

Notes	Comments and Observations
#1	65MHz to 80MHz - low level of interference observed on monitor. Picture still viewable.
#2	Low level of interference observed on monitor - picture still viewable.
#3	No observable effect. Spot frequency measurements made at level of 10Vrms. RF applied using EM clamp. Case of EUT connected to ground plane via 150R. 12V, 0V and video lines connected to ground plane via 450R and 100nF capacitors at AE end of EM clamp. PSU and monitor powered via unterminated CDN. Ferrites on cables to PSU and monitor.

	Report No: R2075	Test Report	Page: 20 of 31
	Issue No: 1		
	Test No: T1622		

4.7 Electrical Fast Transient Immunity Results

EFT

<i>Company:</i> AVO Systems Ltd			<i>Product:</i> CT4 Camera					
<i>Date:</i> 01/06/05			<i>Test Eng:</i> Dave Smith					
Test Equipment: WG4a CL3							RESULT	
<i>Ports:</i>	ac power					Recm'd Crit	Ach'd Crit.	
<i>Tests:</i>	IEC61000-4-4 2kV					(B)	B	
<i>Ports:</i>	signal/control					Recm'd Crit	Ach'd Crit.	
<i>Tests:</i>	IEC61000-4-4 1kV					(B)	B	
<i>Ports:</i>						Recm'd Crit	Ach'd Crit.	
<i>Tests:</i>								
Test	Oper. Mode	Mod State	Transients Applied to:		Level kV	Polarity	Duration s	Notes
1	1	0	DC power	+ ve	2	+	180	#1
2	1	0	DC power	gnd	2	+	180	#1
3	1	0	DC power	+ ve	2	-	180	#1
4	1	0	DC power	gnd	2	-	180	#1
5	1	0	DC power	gnd & + ve	2	+	180	#1
6	1	0	DC power	gnd & + ve	2	-	180	#1
7	1	0	combined power & video cable		1	+	180	#2
8	1	0	combined power & video cable		1	-	180	#2

L = Live, N = Neutral, E = Earth #1, 2, 3... see Observations Table below

Notes	Comments and Observations
#1	Some interference on display during test. Recovered automatically after test. Applied via coupling network. 2.5KHz repetition rate.
#2	Some interference on display during test. Recovered automatically after test. Applied via capacitive clamp. 5KHz repetition rate.

4.8 Electrostatic Discharge Immunity Results

ESD

<i>Company:</i> AVO Systems Ltd				<i>Product:</i> CT4 Camera				
<i>Date:</i> 01/06/05				<i>Test Eng:</i> Dave Smith				
Test Equipment: WG4d WGH3								RESULT
<i>Ports:</i>				Recm'd Crit		Ach'd Crit.		
<i>Tests:</i>	IEC61000-4-2	8kV air		(B)		N/A		
<i>Ports:</i>				Recm'd Crit		Ach'd Crit.		
<i>Tests:</i>	IEC61000-4-2	6kV contact		(B)		B		
<i>Ports:</i>				Recm'd Crit		Ach'd Crit.		
<i>Tests:</i>								

Test	Oper. Mode	Mod State	Discharges Applied to:	+ 6kV cont	- 6kV cont	+ 2kV air	- 2kV air	+ 4kV air	- 4kV air	+ 8kV air	- 8kV air
1	1	0	horizontal coupling plane	#1	#1						
2	1	0	vertical coupling plane	#1	#1						
3	1	0	case	#1	#1						

#1, 2, 3.... see Observations Table below

Notes	Comments and Observations
#1	Brief interference on small area of display. Recovered automatically immediately after test.

	Report No: R2075	Test Report	Page: 22 of 31
	Issue No: 1		
	Test No: T1622		

4.9 Voltage Dips Immunity Results

Voltage Dips

<i>Company:</i> AVO Systems Ltd		<i>Product:</i> CT4 Camera	
<i>Date:</i> 01/06/05		<i>Test Eng:</i> Dave Smith	
Test Equipment:			RESULT
<i>Ports:</i>	ac power		Recm'd Crit
<i>Tests:</i>	EN60945	+/- 20% voltage 1.5s	(B)
<i>Ach'd Crit:</i>			N/A
<i>Ports:</i>	ac power		Recm'd Crit
<i>Tests:</i>	EN60945	+/-10% frequency 100msec	(B)
<i>Ach'd Crit:</i>			N/A
<i>Ports:</i>	power		Recm'd Crit
<i>Tests:</i>	IEC61000-4-11	100% reduction 60s	(C)
<i>Ach'd Crit:</i>			C
<i>Ports:</i>			Recm'd Crit
<i>Tests:</i>			Ach'd Crit.

Test	Oper. Mode	Mod State	Voltage Reduction	Period	Number Applied	Notes
1	1	0	100%	60sec	3	#1

Notes	Comments and Observations
#1	Equipment recovered automatically after power was restored.

Chase EMS 6.21

Notes

Analyse 050801 C1L 200nF

Test: 9kHz-30MHz (L1+CSET001) dBuV

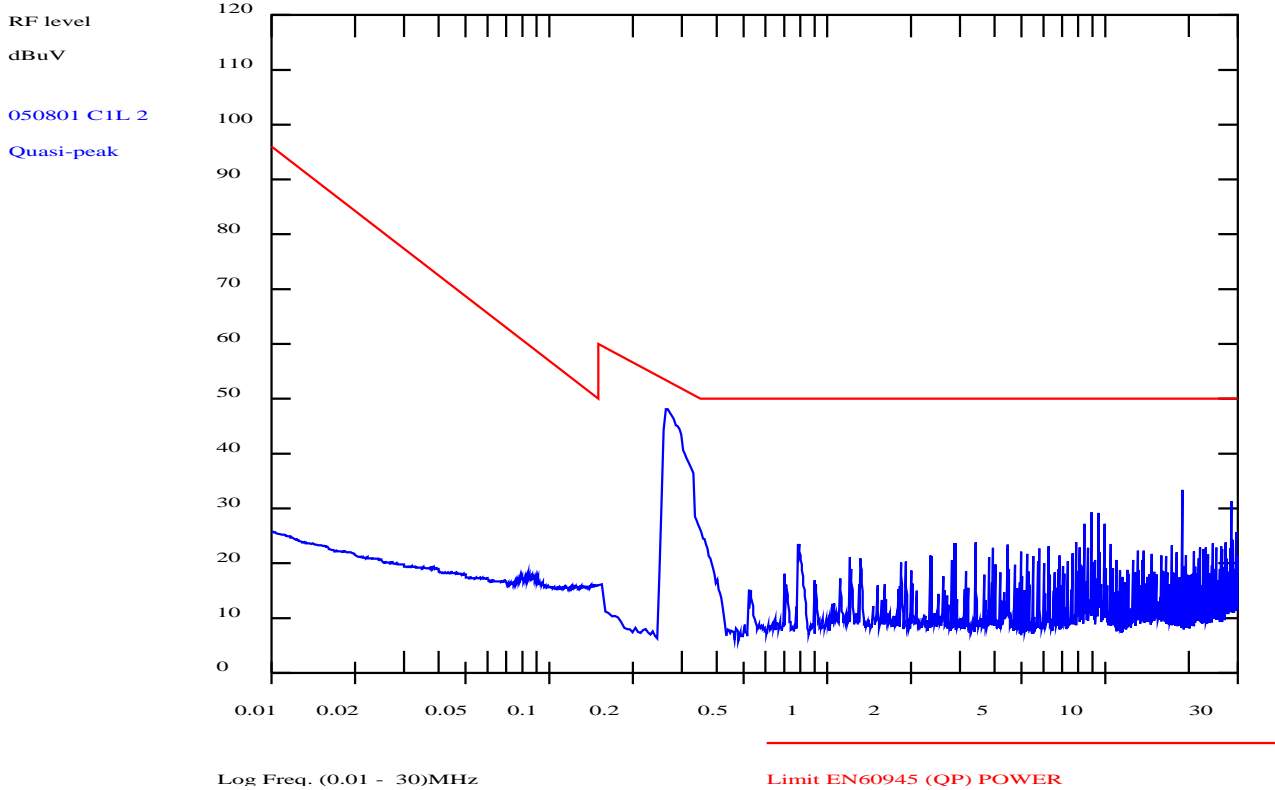

PLOT 1 Conducted Emissions - Positive Line

Company:	AVO Systems	Product:	CT4 camera
Date:	01 Aug 05	Test Engineer:	Dave Smith
Test:	EN60945	Limit:	EN60945
Notes:			
Op.Mode: Camera powered connected to monitor.			
Camera dc power fed through L1. EUT on ground plane.			
Mod.State: 200nF between 0V and 12V pins of camera pcb connector. Overall screened cable.			
Equip:R1,L1,AB002,CBL005,Patch5,CBL007.			
Line:	Positive	Attenuator:	10dB PAD
Detector:	QuasiPeak	Operating Mode:	1
LISN:	EMCO	Mod. State:	1
		Filename:	C582479B.plt

Frequency List (MHz)

Chase EMS 6.21

Notes

Analyse 050801 C2N 200nF

Test: 9kHz-30MHz (L1+CSET001) dBuV

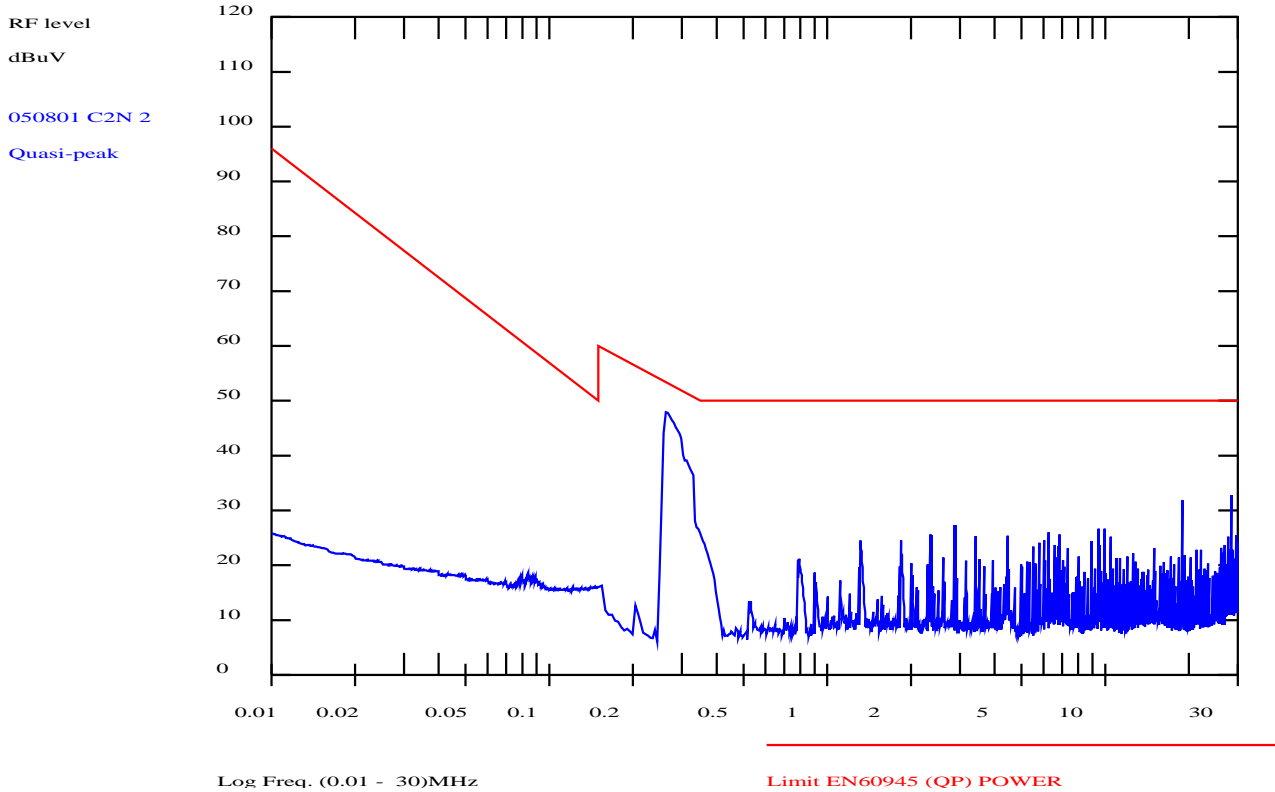

PLOT 2 Conducted Emissions - Negative Line

Company:	AVO Systems	Product:	CT4 camera
Date:	01 Aug 05	Test Engineer:	Dave Smith
Test:	EN60945	Limit:	EN60945
Notes:			
Op.Mode: Camera powered connected to monitor.			
Camera dc power fed through L1. EUT on ground plane.			
Mod.State: 200nF between 0V and 12V pins of camera pcb connector. Overall screened cable.			
Equip:R1,L1,AB002,CBL005,Patch5,CBL007.			
Line:	Negative	Attenuator:	10dB PAD
Detector:	QuasiPeak	Operating Mode:	1
LISN:	EMCO	Mod. State:	1
		Filename:	C58247A0.plt

Frequency List (MHz)

Chase EMS 6.21

Notes

Analyse 050531 H1 - pol 1

Test: EN60945

RF level

dBuV

050531 H1 -

Quasi-peak

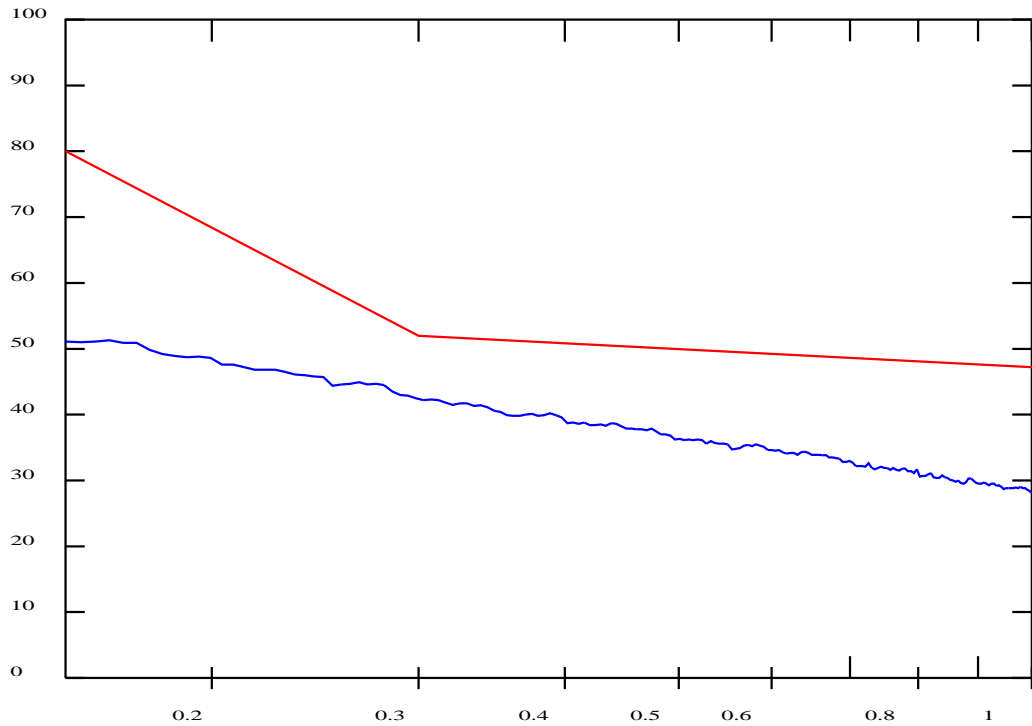

Log Freq. (0.15 - 1)MHz

Limit EN60945

PLOT 3 Radiated Emissions - 0.15MHz to 1MHz (face on polarisation)

Company:	AVO	Product:	CT4
Date:	31 May 05	Test Engineer:	Dave Smith
Test:	EN60954	Limit:	H field
Notes:			
Equip: R1,CBL002,Patch1,CBL003,A9.			
Polarisation:	Face	Orientation:	side
Distance:	3m	Antenna:	LOOP
Height:	1m	Filename:	C582478F.plt
		Operating Mode:	1
		Mod. State:	0

Frequency List (MHz)

Chase EMS 6.21

Notes

Analyse 050531 H2 plo 2

Test: EN60945

RF level

dBuV

050531 H2 pl

Quasi-peak

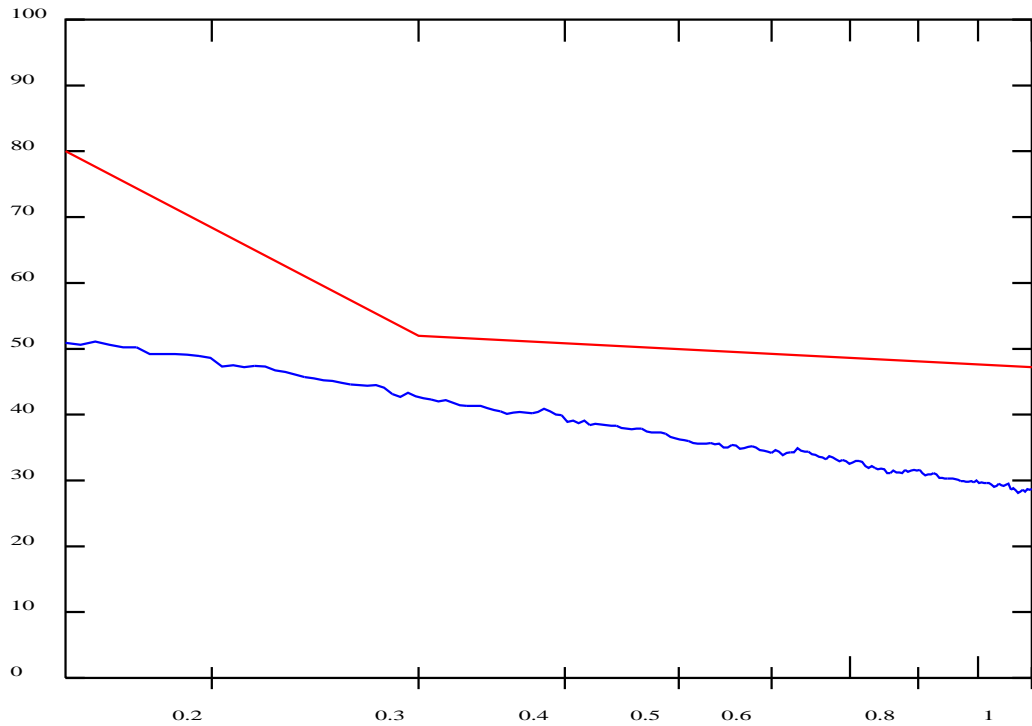

Log Freq. (0.15 - 1)MHz

Limit EN60945

PLOT 4 Radiated Emissions - 0.15MHz to 1MHz (side on polarisation)

Company:	AVO	Product:	CT4
Date:	31 May 05	Test Engineer:	Dave Smith
Test:	EN60954	Limit:	H field
Notes:			
Equip: R1,CBL002,Patch1,CBL003,A9.			
Polarisation:	Side	Orientation:	side
Distance:	3m	Antenna:	LOOP
Height:	1m	Filename:	C5824791.plt
		Operating Mode:	1
		Mod. State:	0

Frequency List (MHz)

hp

REF 90.0 μ V #AT 0 dB MKR 1.000 MHz 40.18 dB μ V

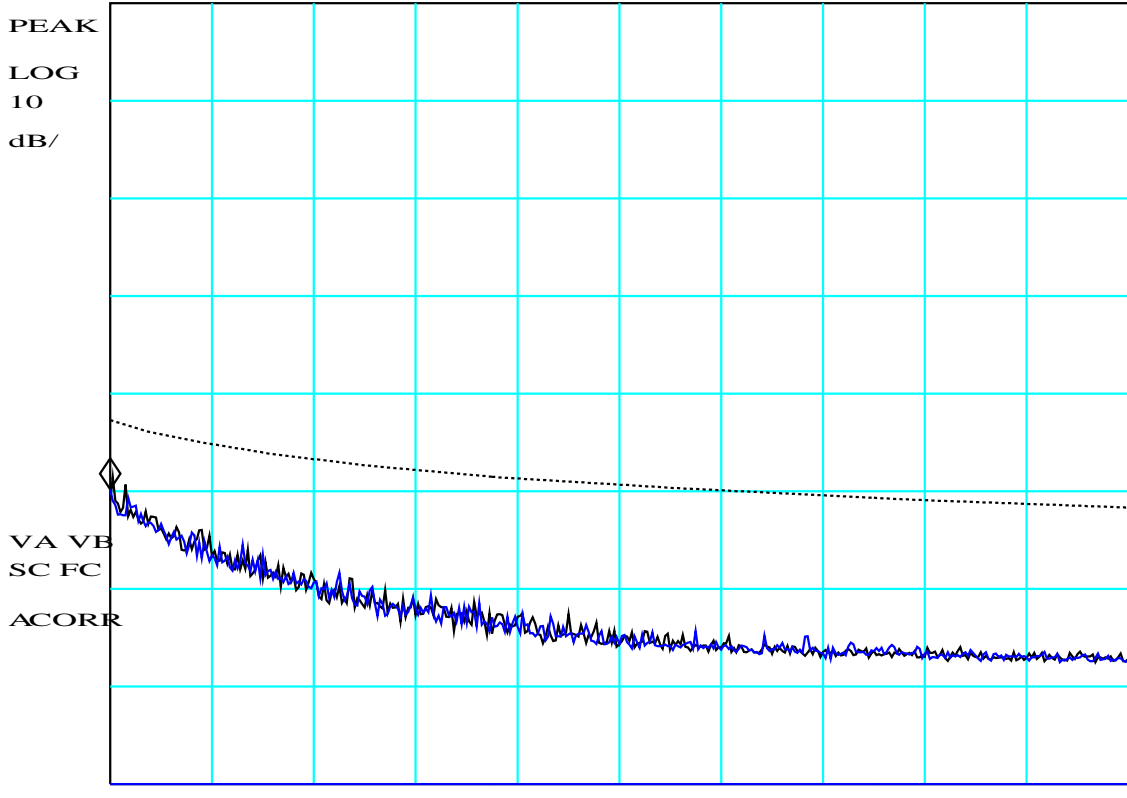

START 1.000 MHz STOP 10.000 MHz
 #RES BW 9.0 kHz VBW 30 kHz SWP 333 msec

PLOT 5 Radiated Emissions - 1MHz to 10MHz

Company:	AVO Systems	Product:	CT4 camera
Date:	31 May 05	Test Engineer:	Peter Barlow
Test:	EN60945	Limit:	EN60945
Notes:			
Op.Mode: Camera Only (powered via dB 12V bench supply).			
Mod.State: No mods.			
Equip: R5,CBL002,Patch1,CBL003,A9		Edge On- Black Trace, Face On - Blue Trace	
Polarisation:	E + F	Orientation:	0 - 360°
Distance:	3m	Antenna:	Mag Loop
Height:	1m	Filename:	H5531749.plt
		Operating Mode:	1
		Mod. State:	0

Frequency List (MHz)

hp

REF 90.0 μ V #AT 0 dB MKR 10.00 MHz
 23.51 μ V

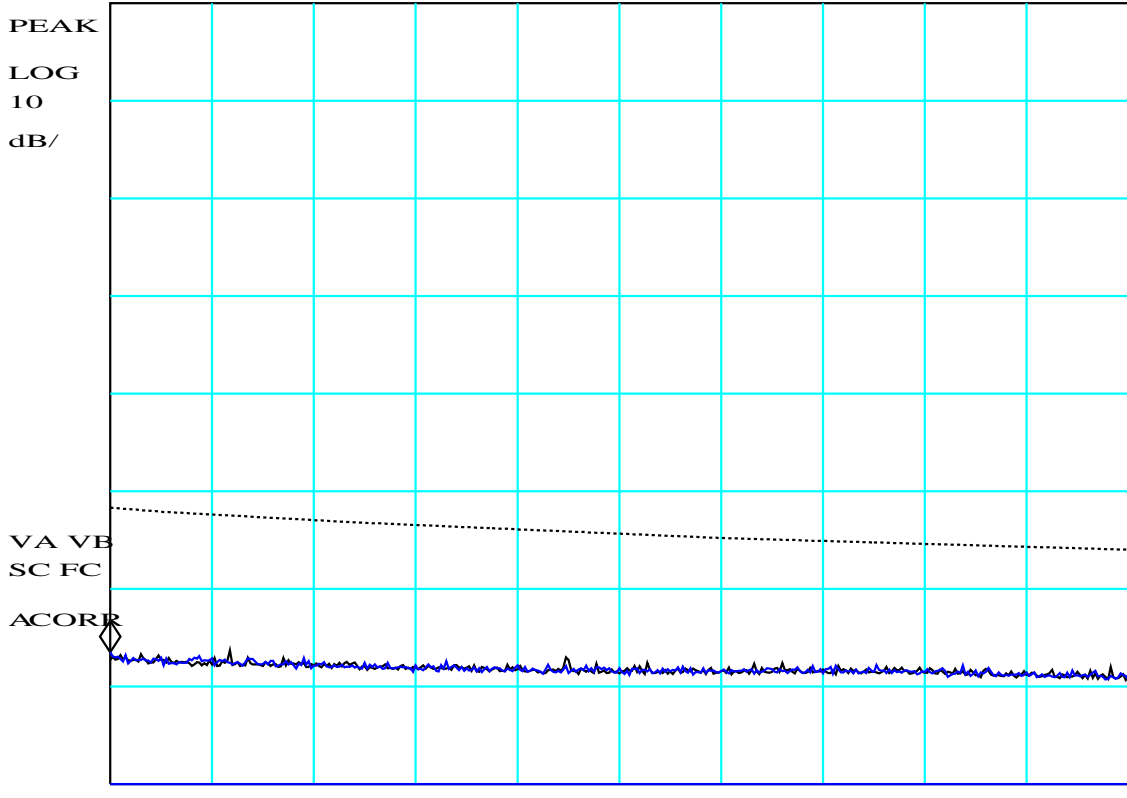

START 10.00 MHz STOP 30.00 MHz
 #RES BW 9.0 kHz VBW 30 kHz SWP 741 msec

PLOT 6 Radiated Emissions - 10MHz to 30MHz

Company:	AVO Systems	Product:	CT4 camera
Date:	31 May 05	Test Engineer:	Peter Barlow
Test:	EN60945	Limit:	EN60945
Notes:			
Op.Mode: Camera Only (powered via dB 12V bench supply).			
Mod.State: No mods.			
Equip: R5,CBL002,Patch1,CBL003,A9		Edge On- Black Trace, Face On - Blue Trace	
Polarisation:	E + F	Orientation:	0 - 360°
Distance:	3m	Antenna:	Mag Loop
Height:	1m	Filename:	H553174F.plt
		Operating Mode:	1
		Mod. State:	0

Frequency List (MHz)

hp

REF 60.0 dBV #AT 0 dB PG 14.0 dB MKR 161.3 MHz
 20.32 dBV

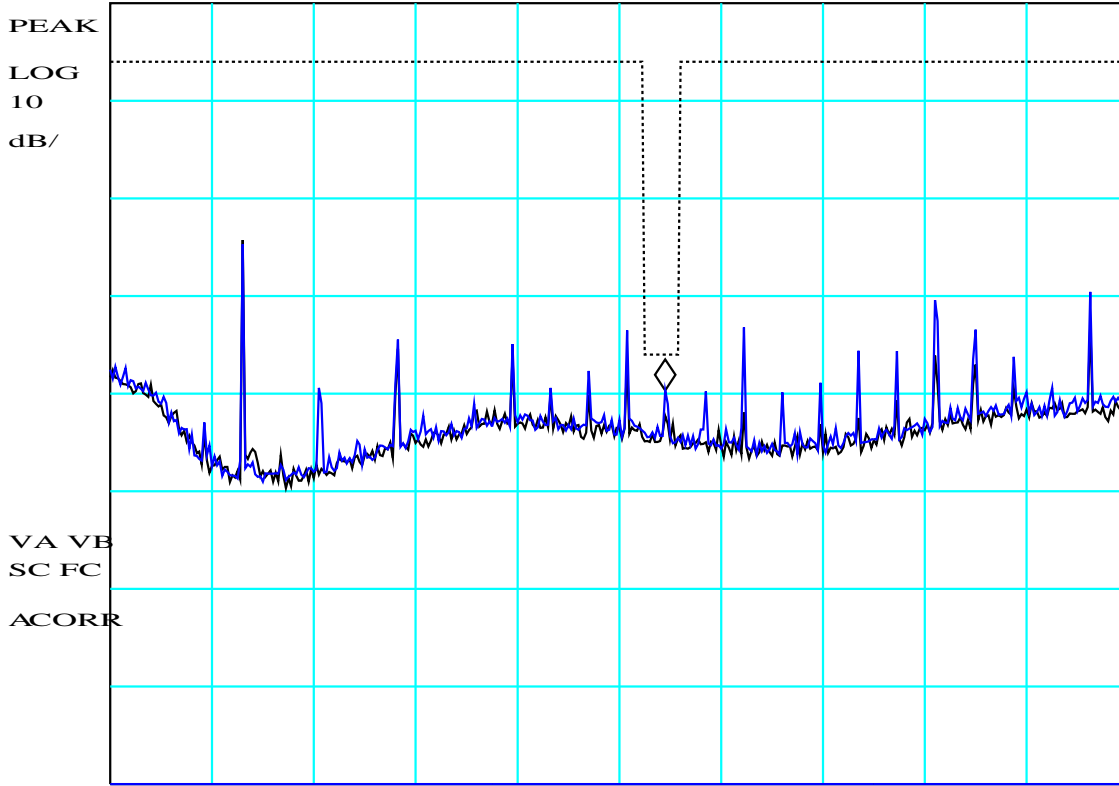

START 25.0 MHz STOP 275.0 MHz
 #RES BW 120 kHz VBW 300 kHz SWP 52.1 msec

PLOT 7 Radiated Emissions - 25MHz to 275MHz

Company:	AVO Systems	Product:	CT4 camera
Date:	31 May 05	Test Engineer:	Peter Barlow
Test:	EN60945	Limit:	EN60945
Notes:			
Op.Mode: Camera Only (powered via dB 12V bench supply).			
Mod.State: No mods.			
Equip: R5,RB5,CBL002,Patch1,CBL003,A12 Vertical - Black Trace, Horizontal - Blue Trace			
Polarisation:	V + H	Orientation:	0 - 360°
Distance:	3m	Antenna:	Bilog
Height:	1m	Filename:	H5531786.plt
		Operating Mode:	1
		Mod. State:	0

Frequency List (MHz)

hp

MKR 966.2 MHz

REF 60.0 dBµV #AT 0 dB PG 14.0 dB 32.29 dBµV

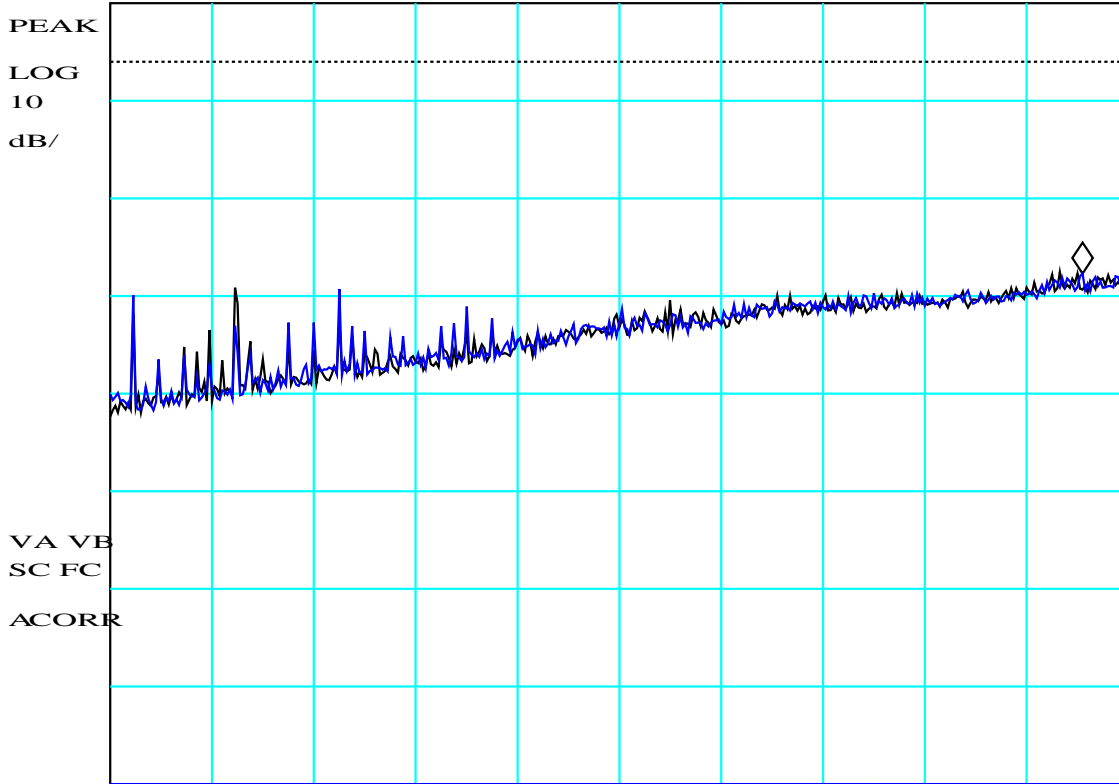

START 250.0 MHz STOP 1.0000 GHz

#RES BW 120 kHz VBW 300 kHz SWP 156 msec

PLOT 8 Radiated Emissions - 250MHz to 1GHz

Company:	AVO Systems	Product:	CT4 camera
Date:	31 May 05	Test Engineer:	Peter Barlow
Test:	EN60945	Limit:	EN60945
Notes:			
Op.Mode: Camera Only (powered via dB 12V bench supply).			
Mod.State: No mods.			
Equip: R5,RB5,CBL002,Patch1,CBL003,A12 Vertical - Black Trace, Horizontal - Blue Trace			
Polarisation:	V + H	Orientation:	0 - 360°
Distance:	3m	Antenna:	Bilog
Height:	1m	Filename:	H553178D.plt
		Operating Mode:	1
		Mod. State:	0

Frequency List (MHz)

hp

REF 60.0 dBµV #AT 0 dB PG 36.0 dB MKR 1.745 GHz
 24.16 dBµV

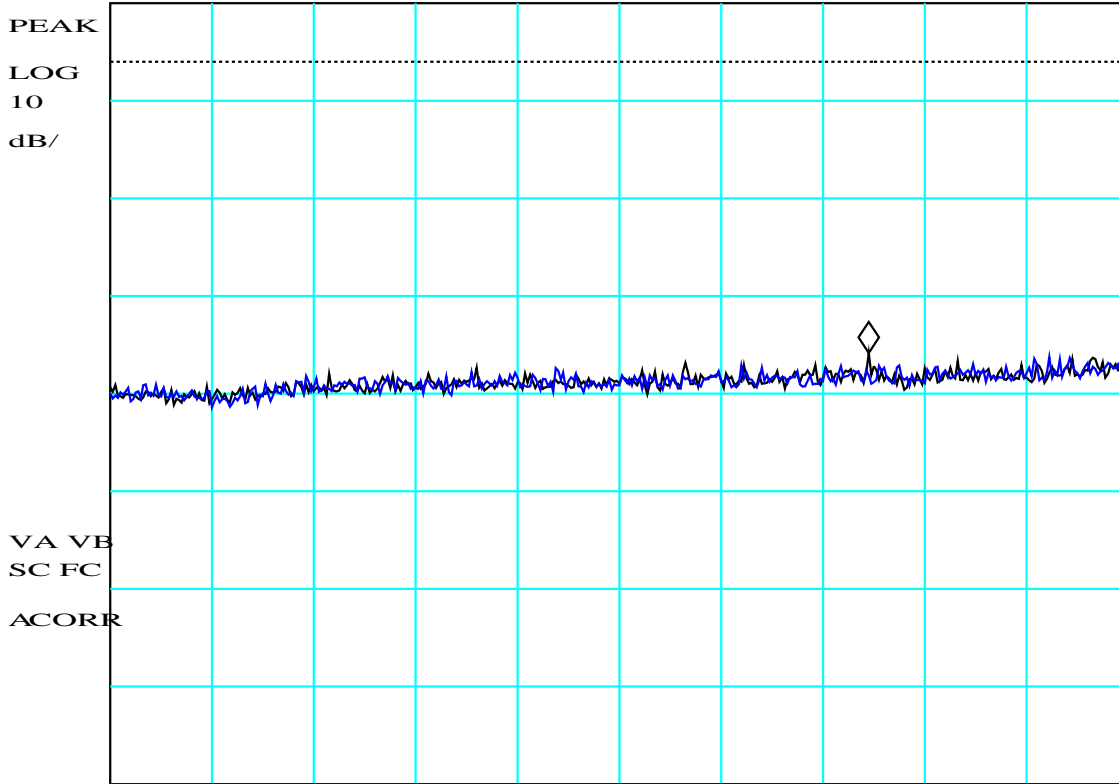

START 1.000 GHz STOP 2.000 GHz
 #RES BW 120 kHz VBW 300 kHz SWP 208 msec

PLOT 9 Radiated Emissions - 1GHz to 2GHz

Company:	AVO Systems	Product:	CT4 camera
Date:	31 May 05	Test Engineer:	Peter Barlow
Test:	EN60945	Limit:	EN60945
Notes:			
Op.Mode: Camera powered connected to TFT monitor. Monitor powered displaying Image.			
Mod.State: No modifications EUT tested as received 31/05/05.			
Equip: R5,PRE3,CBL043,Patch1,CBL044,A8 Vertical- Black Trace, Horizontal - Blue Trace			
Polarisation:	V + H	Orientation:	0 - 360°
Distance:	3m	Antenna:	DRG
Height:	1m	Filename:	H55315B7.plt
		Operating Mode:	1
		Mod. State:	0

Frequency List (MHz)
